

# FK36BI-LS1

36", FRIDGE AND FREEZER, OT Model

BUILT-IN

CLASSIC® SERIE

*Fhiaba*



## FEATURES

- Made in Italy.
- Aisi 304 stainless steel body.
- Aluminium interior finish
- Antibacterial stainless steel interior.
- Evenlift: shelves can slide up and down to be adjusted to any height in the fridge compartment.
- Provent ventilation system encourages uniform distribution of cold air in all fridge compartments by laterally circulation air.
- Equilance: dual - movemenet patented hinge with self - balancing movement ensures stability and resistance.
- Optiview: multi - LED light array (top and side interior) provides brilliant illumination to the entire interior.
- Soft close door and drawers in all compartments
- Smart touch TFT display
- Acoustic and visual signals
- Total no frost 100% automatic system
- Variable speed compressors maintains precision temperature control with low vibration.
- Sabbath mode
- Front and rear adjustable feet up to 25 mm.
- Two independent climatic zone.
- Tempered glass shelves with aluminium profiles.
- Crisper drawers for multi - use preservazion solution. Antibacterial stainless steel interior & rounded corners promoting hygiene and easy cleaning.
- Deep capacity within a standard depth is achieved by a side - mounted evaporators, wich leaves grater interior space.
- Full range of models and configurations ( 18", 24", 30" and 36"). Can easily be combined and configured with other Fhiaba fridge, freezer, wine cellar models to fit your kitchen needs.

## GENERAL PROPERTIES

Reversible door	NO
Equilance	YES
SoftClosing Runner	YES
Low vibration	YES
Optiview (LED light spots)	YES
Shelves	2
Slide-out shelves	NO
Type of shelves	GLASS
Door Bins	3
Fridge drawers type	LOW TEMP
Fresco/LowTemp Drawers	2
Bottom drawers	1
Full Extension shelves 90° door opening	YES
Full Extension drawers 90° door opening	YES
Defrost Process	AUTOMATIC
Ice maker with water filter	YES
Door Open Alarms	YES
Humidity control	NO
Active carbon filter	NO
Air filter control	NO
Shopping Fridge	YES
Shopping Freezer	YES
Power Failure Function	YES

# FK36BI-LS1

36", FRIDGE AND FREEZER, OT Model

BUILT-IN

CLASSIC® SERIE

## PRODUCT DETAIL

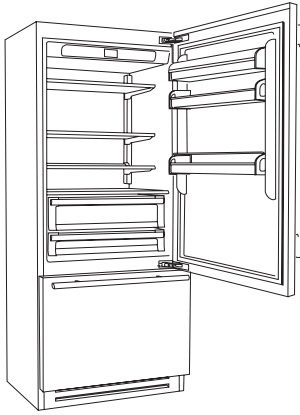

**Fhiaba**

OT

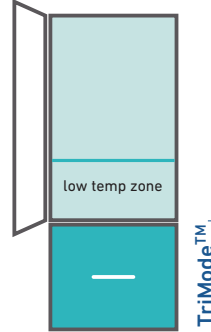

1D | 1BD | 2M

**D** = door

**BD** = drawer

**M** = separate microclimates

### CAPACITY

Capacity (cbf)	18.7
Compartment 1 / Upper wine cellar capacity (bottles)	
Compartment 2 / Lower wine cellar capacity (bottles)	
Compartment 3 / Bottom wine cellar capacity (bottles)	

### TECHNICAL DETAILS

Absorbed power (W)	
Total absorbed current (A)	2.05
Voltage (V)	115
Frequency (Hz)	60
Power Cord Length (in)	78" 3/4
Plug Type	3-prong (15 Amp)
Climatic class	SN/T
Refrigerant (gas)	R134a
Water connection / female attachment	3/4" NPT (1/4" elbow)

### EFFICIENCY

Estimated Yearly Electricity Use	580
----------------------------------	-----

### DIMENSIONS & WEIGHT

Height of the product (closed weels) (in)	83" 1/2 (2120 mm)
Adjustable feet height (in)	1" (25 mm)
Width of the product (in)	36" (913 mm)
Depth of Product without handle (in)	25" (635 mm)
Wall cavity height (in)	84" (2134 mm)
Wall cavity width (in)	36" (914 mm)
Wall cavity depth (in)	min 25" (635 mm) + panel thickness for flush install
Net Weight (lbs)	472 (214 kg)
Gross Weight (lbs)	518 (235 kg)

### TEMPERATURE RANGES

Climatic compartments	2
Compartment 1 / Upper temperature (°F)	from 1 to 7
Compartment 2 / Middle temperature (°F)	
Low temp zone	YES
Compartment 3 / Low temperature (°F)	from -13 to -23
Dual zone	NO

# FK36BI-LS1

36", FRIDGE AND FREEZER, OT Model

BUILT-IN

CLASSIC® SERIE

## PRODUCT SPECIFICATIONS AND DIMENSIONS

*Fhiaba*

FRONT VIEW

SIDE VIEW

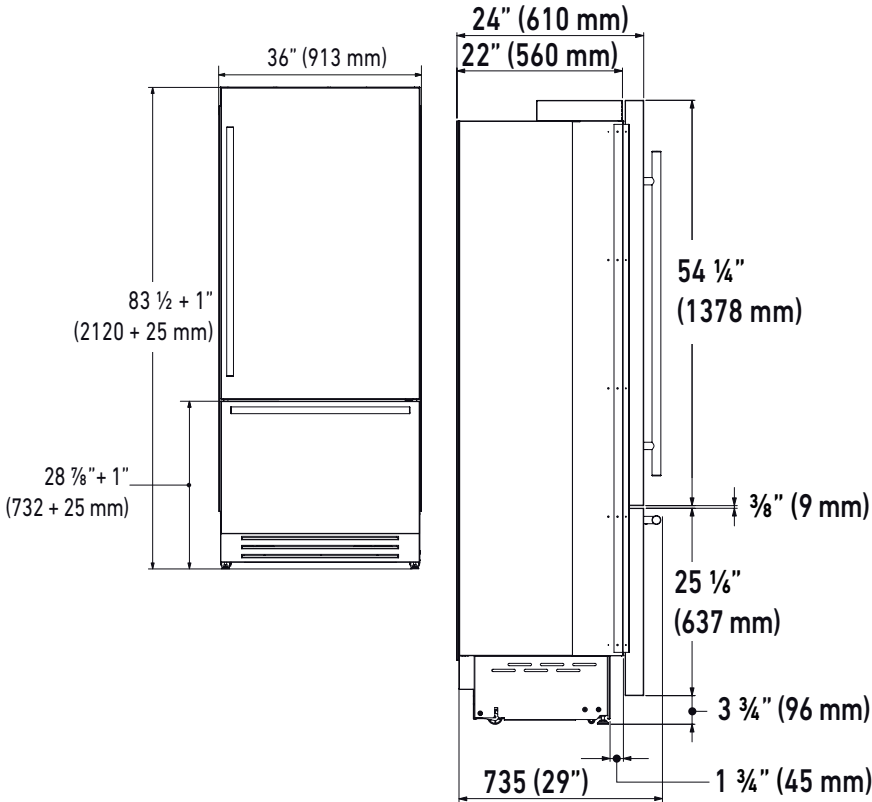

TOP VIEWS,

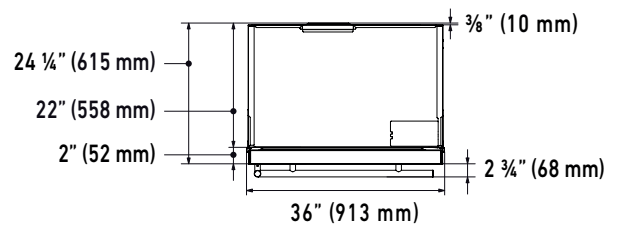
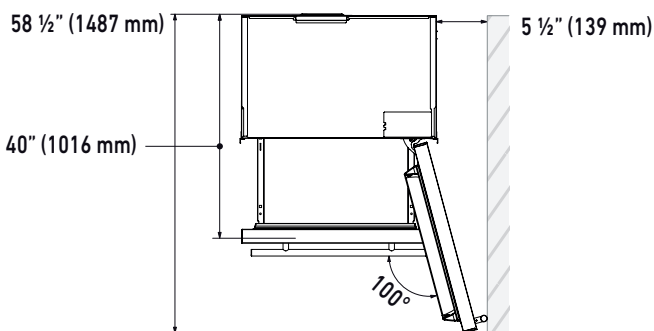

**i** For installation specifications, please consult with Fhiaba. For optimum installation, we recommend using the actual product as the best guide.

**i** Based on the adjustment of the feet and the height of the panel from the floor, the customer defines the perforated plinth to be installed on the equipment.

# FK36BI-LS1

36", FRIDGE AND FREEZER, OT Model

BUILT-IN

CLASSIC® SERIE

## NICHE SPECIFICATIONS AND DIMENSIONS

*Fhiaba*

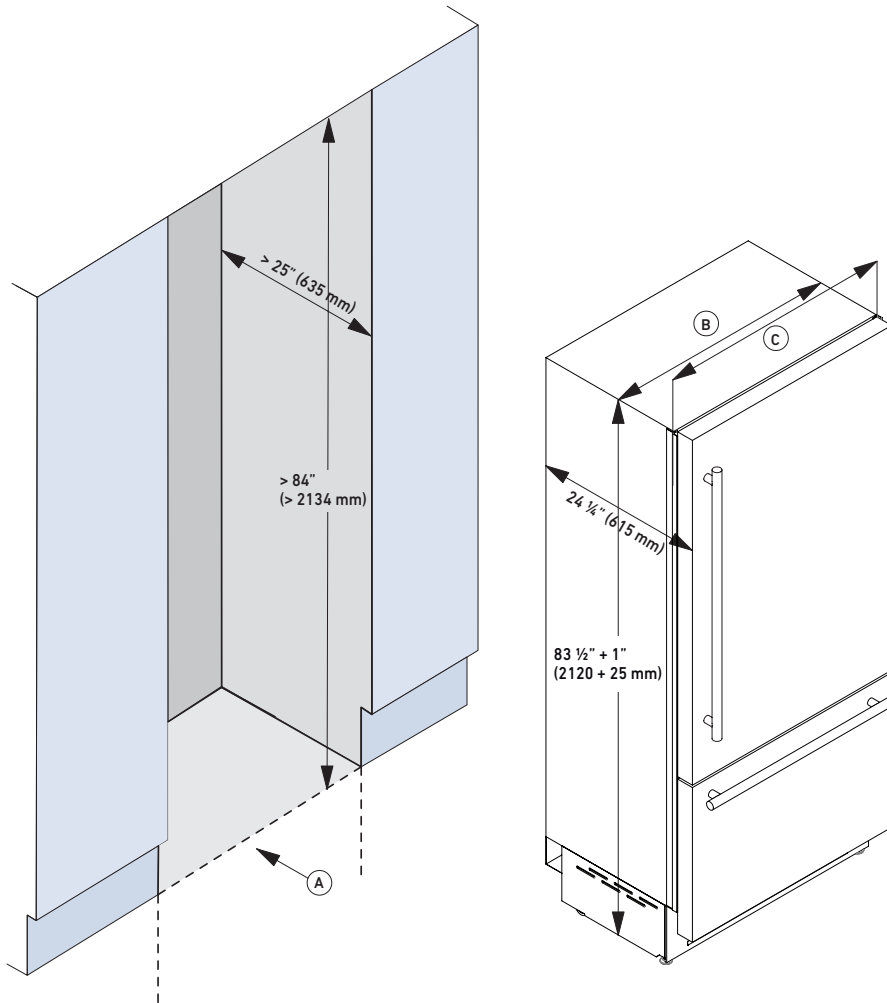

### PLINTH SIZE

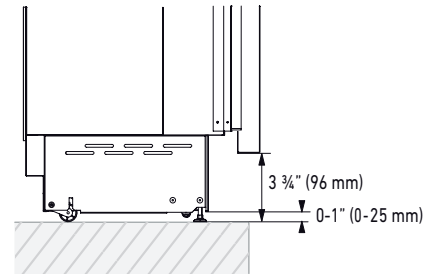

TECHNICAL DATA	
Niche Width <b>A</b> (mm)	36"
Unit Width <b>B</b> (mm)	34" 7/8
Unit Width with lateral frames <b>C</b> (mm)	36"

### Electrical and Water connection

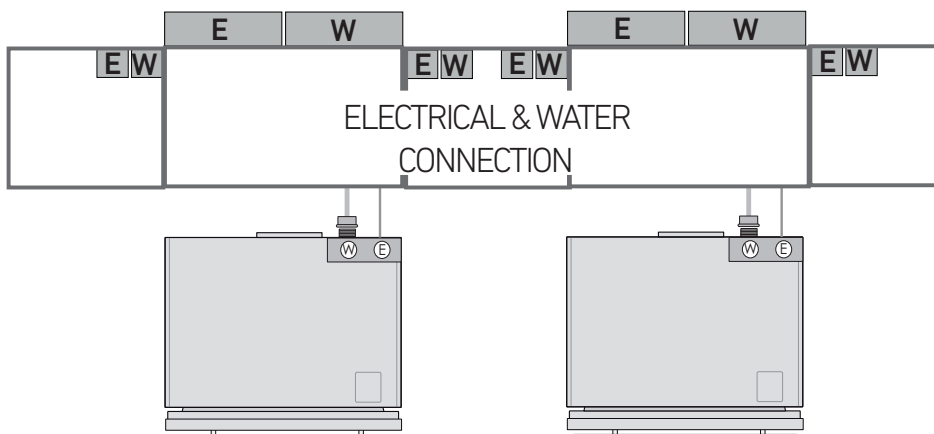

# FK36BI-LS1

36", FRIDGE AND FREEZER, OT Model

BUILT-IN

CLASSIC® SERIE

## INSTALLATION INFORMATION



### Niche dimensions for combined installation

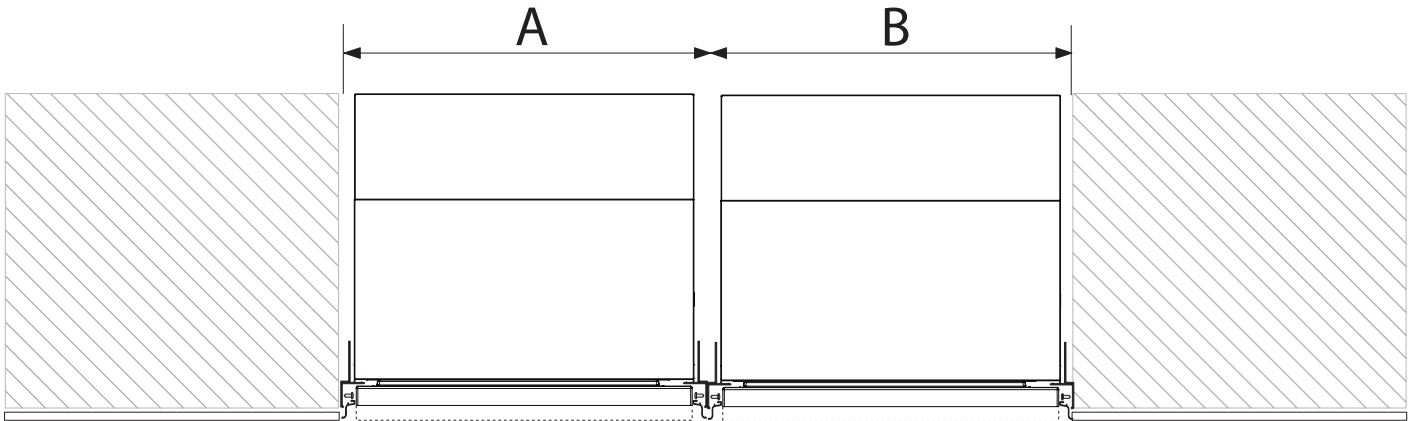

		A			
		18"	24"	30"	36"
B	18"	36"(914mm)	42"(1067mm)	48"(1220mm)	54"(1372mm)
	24"	42"(1067mm)	48"(1220mm)	54"(1372mm)	60"(1520mm)
	30"	48"(1220mm)	54"(1372mm)	60"(1520mm)	66"(1676mm)
	36"	54"(1372mm)	60"(1524mm)	66"(1676mm)	72"(1829mm)

### ACCESSORIES

- Stainless steel sides panels
- Glass door
- Ice maker with water filter
- Water filtration system
- Joining kit
- Stainless steel portal for freestanding
- Extra lenght anti-tipping kit
- Anticondensation kit
- Cleaning kit
- Water filter cartridge
- FLD - Fhiaba Link Device
- Front ventilation kit
- Painting
- 90° Door stop

 For installation specifications, please consult with Fhiaba. For optimum installation, we recommend using the actual product as the best guide.

